

**Type 1**

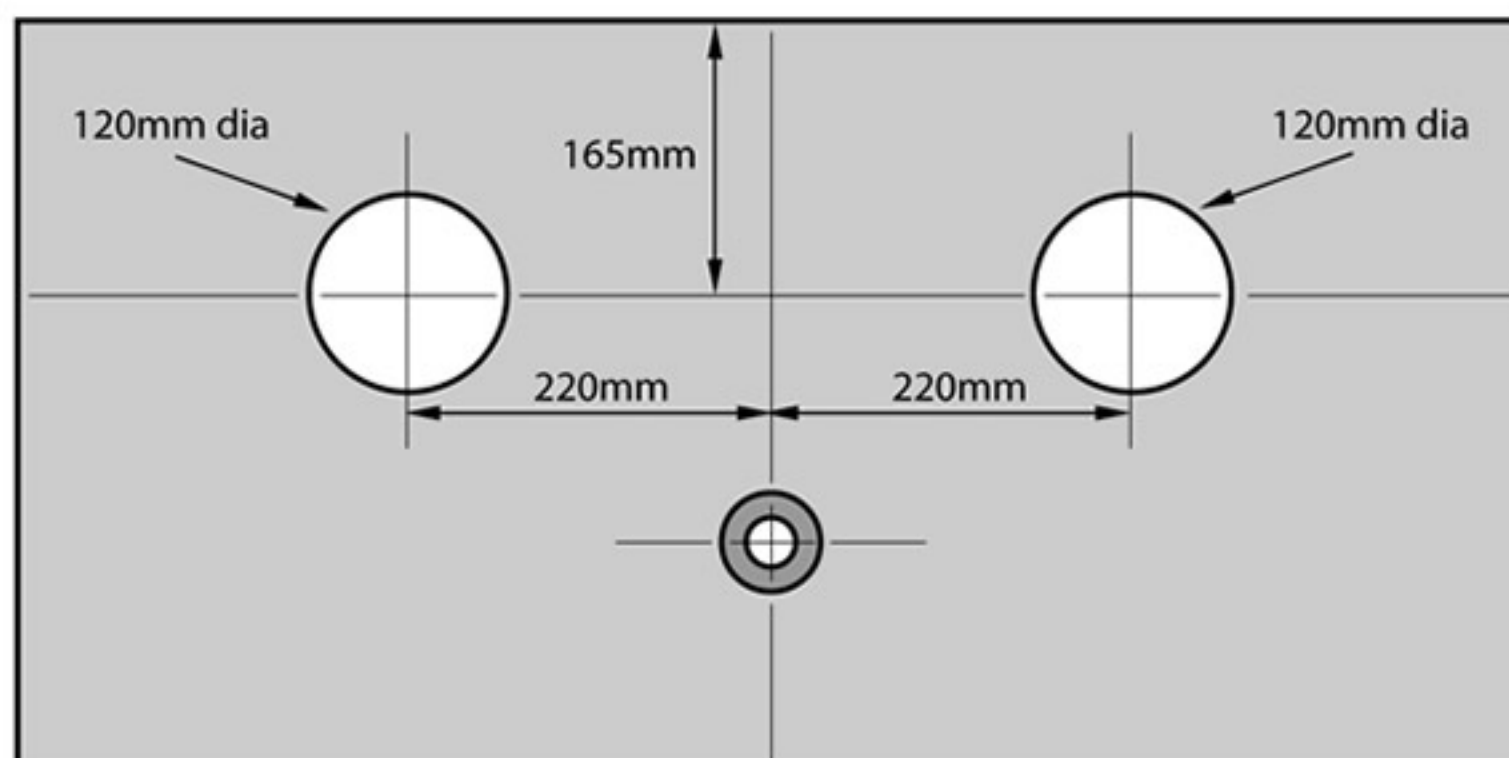
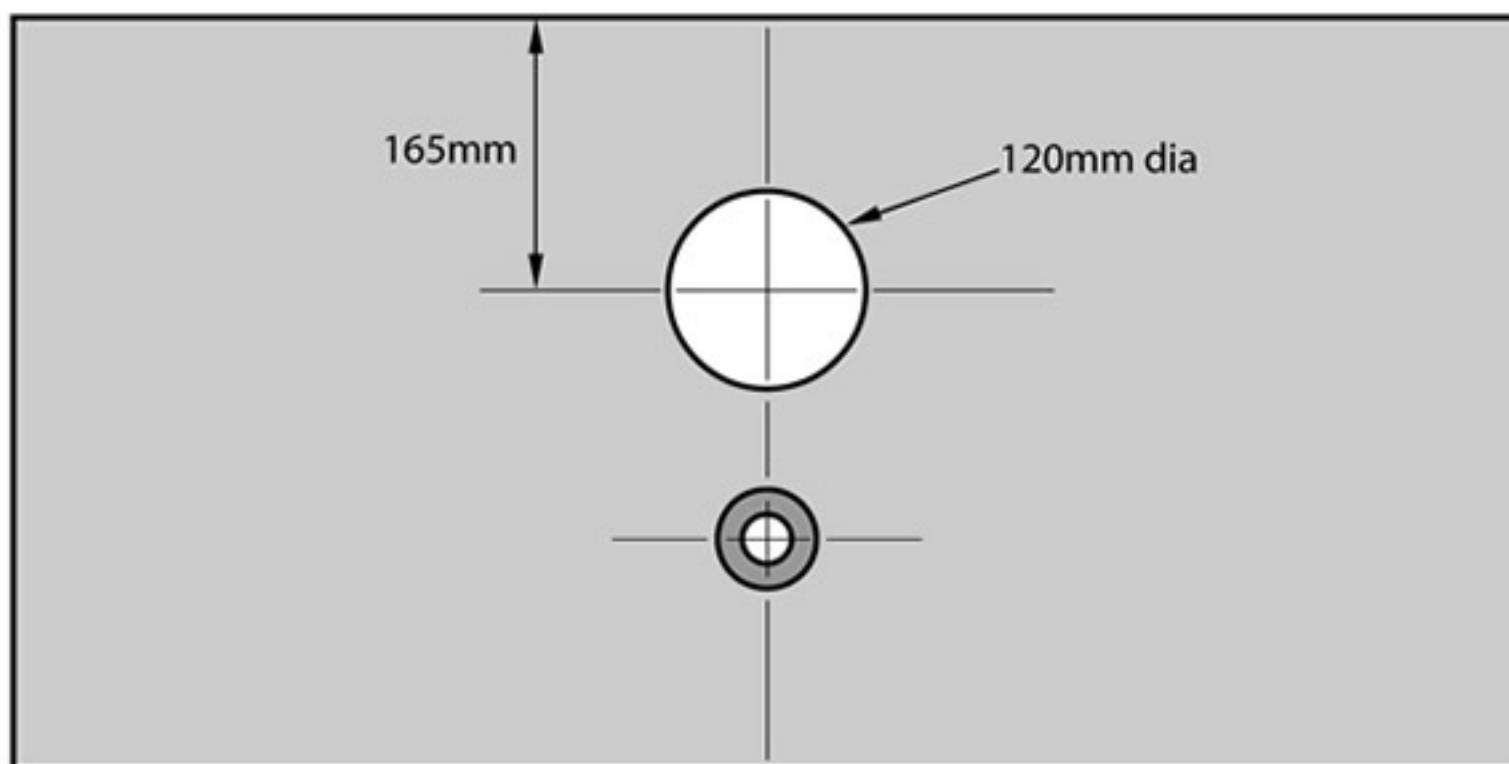
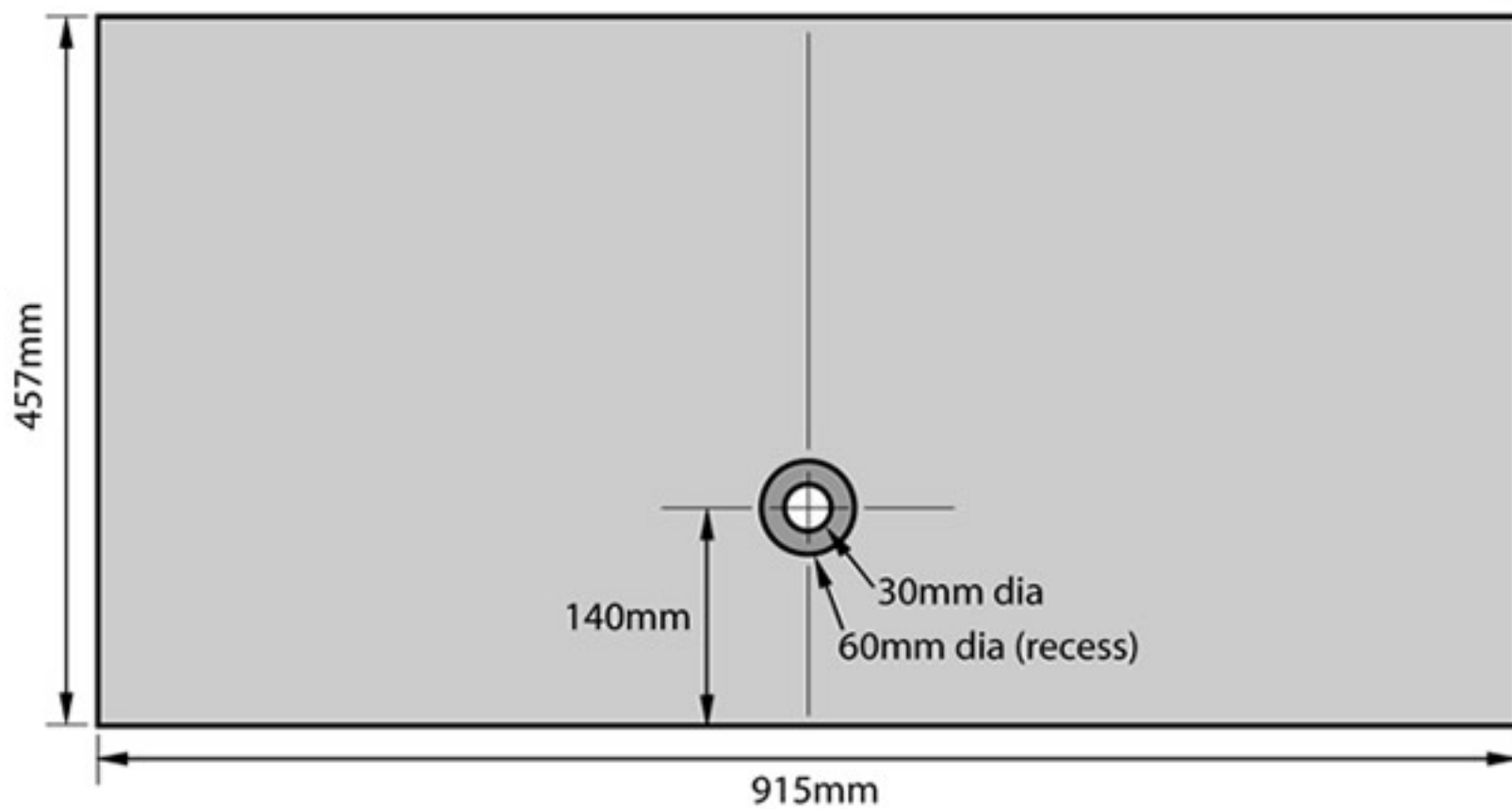

## MEMORIAL FOUNDATION PLINTH

All plinths are manufactured with one fixing/anchor hole and have a combination of vase holes ie. one hole in the centre or two holes off set of the centre.

Also available is a plain plinth with just a fixing hole

The **type 1** plinths are manufactured in either a dense concrete or a lightweight concrete both are fibre reinforced.

All products are manufactured to comply with the provision of BS 8415 : 2005 which require a minimum cement class of 42.5N with cube strengths which exceed the minimum requirement of 30N/mm<sup>2</sup> - Test certificates are available on request from our Technical Department.

**Colours available:** Natural grey or Charcoal.  
*Other colours are available to special order*

**Packaging:** The plinths are shrink wrapped and banded on to non returnable pallets to protect them from the weather and adverse conditions. There are twelve per pallet.

**Delivery:** Delivery can be arranged direct to site on self-unloading vehicles. Every care is taken to ensure that damage does not occur during loading and transit. On site, all plinths should be handled with care and precautions taken to avoid damage to the corners.



**Type 2**

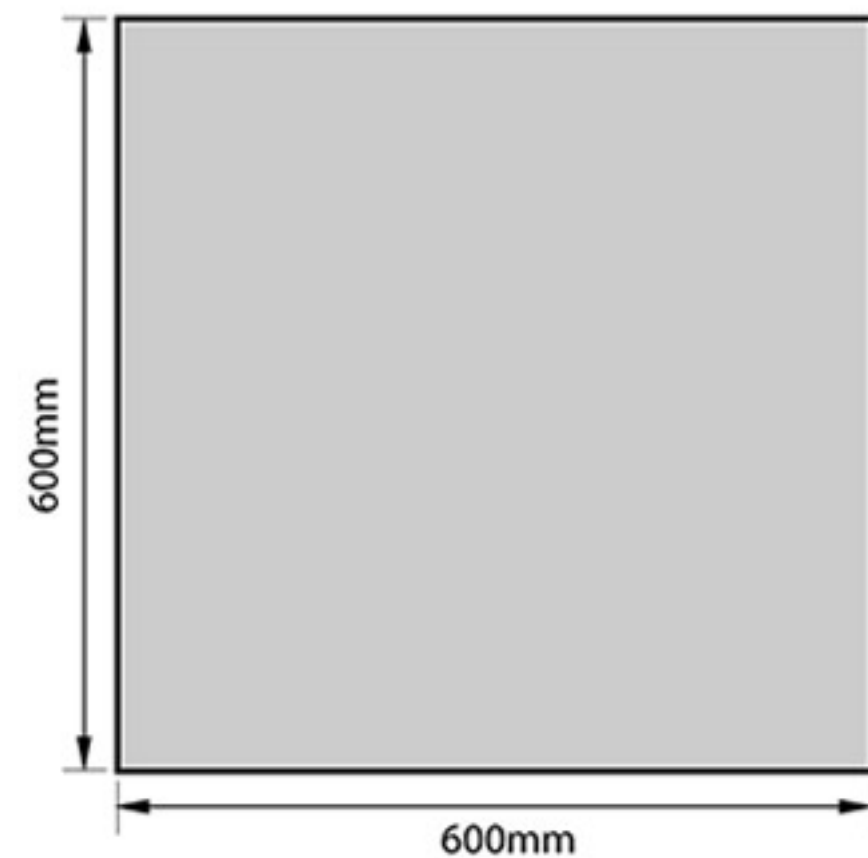
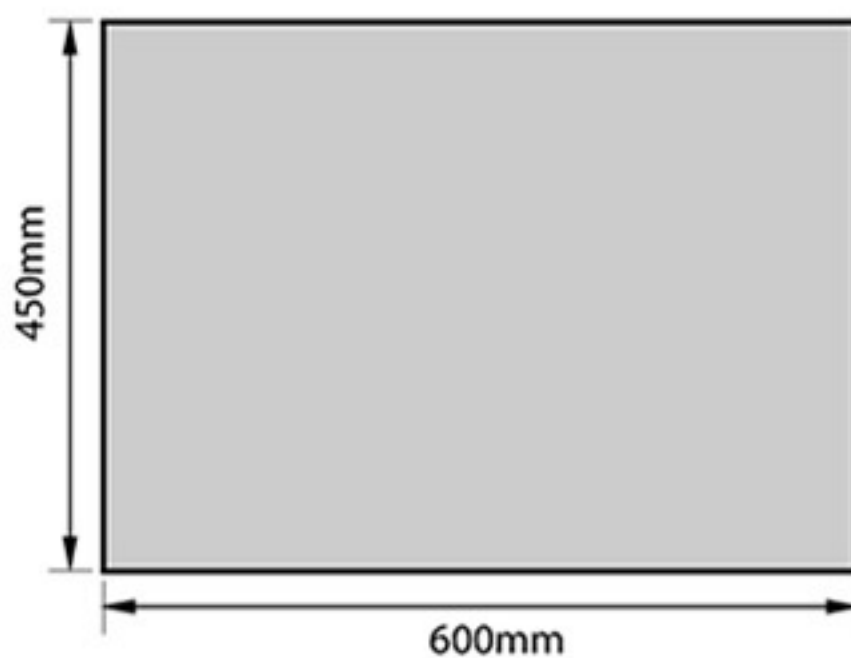

The **type 2** plinths are manufactured in either a dense concrete or a lightweight concrete.

All products are manufactured to comply with the provision of BS 8415 : 2005 which require a minimum cement class of 42.5N with cube strengths which exceed the minimum requirement of 30N/mm<sup>2</sup> - Test certificates are available on request from our Technical Department.

**Colours available:** Natural grey or Charcoal. *Other colours are available to special order*

**Packaging:** The plinths are shrink wrapped and banded on to non returnable pallets to protect them from the weather and adverse conditions. There are ten per pallet.

**Delivery:** Delivery can be arranged direct to site on self-unloading vehicles. Every care is taken to ensure that damage does not occur during loading and transit. On site, all plinths should be handled with care and precautions taken to avoid damage to the corners.

*For further information please contact our Sales Office on 01495 227331*



OLD MILL WORKS, GELLIGROES, PONTLLANFRAITH, BLACKWOOD, GWENT, NP12 2HY.

TEL: 01495 227331 FAX: 01495 222553 E MAIL: [salesupport@gryphonn.co.uk](mailto:salesupport@gryphonn.co.uk)

WEBSITE: [www.gryphonn.co.uk](http://www.gryphonn.co.uk)